

**AEROSTAR INTERNATIONAL, INC.
INSTRUCTIONS FOR INSTALLATION OF:
REPAIR KIT #52733
SERVICE BULLETIN #131**

October 1, 1992

SUBJECT:

The following is a complete instruction set for compliance to S/B #131 for HP3D burners, S/N's HP3D-3001 through HP3D-3334. For more information, please refer to that service bulletin.

CORRECTIVE ACTION:

This corrective action may be performed only by a person authorized under FAR 43.3 for maintenance. This includes mechanics, repairmen and repair stations. Upon completion, the logbook must contain an endorsement to the effect of:

"Maintenance performed on Burner S/N HP3D-XXXX in accordance with Aerostar Service Bulletin #131. Burner HP3D-XXXX has been inspected and is airworthy for return to service."

MM/DD/YY FIRST N. LAST NAME
CER-TIF-NUMB

Tools Required:

Small hammer (no sledge required)
Punch (drift), 3/16" (measures .180" o.d.) and shaft length of at least 1 ¼"
Medium sized tapered Drift
Block of wood, 2 x 4 or 4 x 4, about 9½" long
Stranded packing tape
Leather gloves
Safety goggles (everyone within 50 feet)
"C" clamp or vice-grip pliers, usable span of 4½"
Vice, opening at least 3"
Dial caliper (0-6")

- 1] Obtain from Aerostar, Service Bulletin #131 Repair Kit, P/N 52733. One kit is enough for one HP3D burner ("Zone Five" dual).

The kit includes:

[2] 52348 Gimbal Spring Plate, End
[2] 5101113 Rollpin 3/16 x 1 ¼
[4] 5101740 Wave Spring Washer
[2] 5104044 Thrust Washers
[4] 5101213 Hole Plugs

- 2] At this point, put on your safety glasses and leather gloves.
- 3] Position burner on flat surface, coils down, so that trigger handle is up. Prop the block of wood beneath the gimbal block on the end being repaired.

- 4] Using a hammer and punch, completely drive out both roll pins from the gimbal block and discard the roll pins.

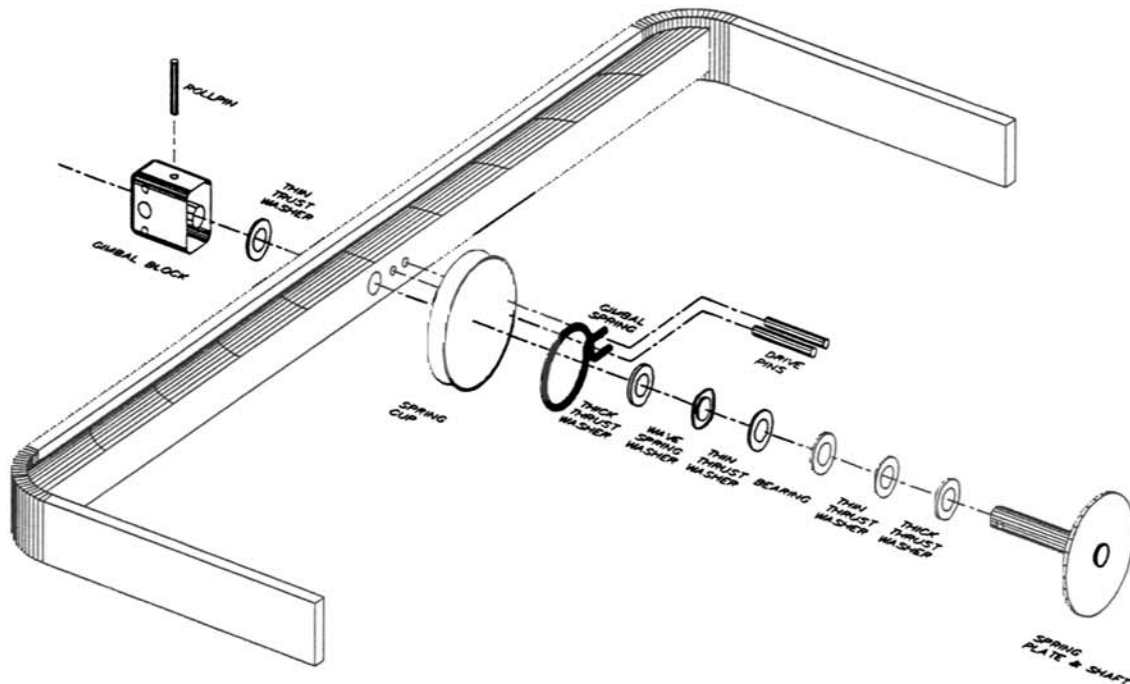

Exploded View

- 5] Slide the gimbal block off of the spring plate shaft. Remove the thin thrust washer from the spring plate shaft. Slowly slide the gimbal spring plate & shaft and rod through the burner frame. Slowly is the key operative here. The spring will snap, so be careful. Remove the gimbal spring plate & shaft, washers, spring and bearing from the burner frame. Remove the inner washers and bearing in stack for re-installation on the new gimbal plate. Remove the spring. Leave the black spring cup installed on the burner frame, holes aligned with the drive pins.
- 6] Inspect the hole in the burner frame for elongation or excessive looseness with a dial caliper. The hole should not be elongated to greater than 0.540" diameter in any direction. Inspect the bearing, clean as necessary. Insert a wave washer from the kit between any two washers (not between a washer and bearing). Apply a small amount of Krytox to the bearing and washers.
- 7] Install the stack of washers and bearing over the shaft of the new gimbal plate, then align and insert it through the spring cup and burner frame. On the outside of the frame, slide the washer and gimbal block (from step 5) over the shaft. Using moderate pressure, you should be capable of squeezing the block and the gimbal plate together enough to align the roll-pin holes on the block and the shaft (you will be using the hole closest to the outside end of the gimbal block). It may be necessary to use a "C" clamp to squeeze the two together to get perfect alignment of the holes. If this doesn't work, disassemble and replace a thick washer in the bearing and washer stack with a thinner thrust washer from the service bulletin kit.

Reassemble and check again for hole alignment. [Moderate pressure should be necessary to compress the spring washer during assembly]. No noticeable end-play should be present upon completion of this step.

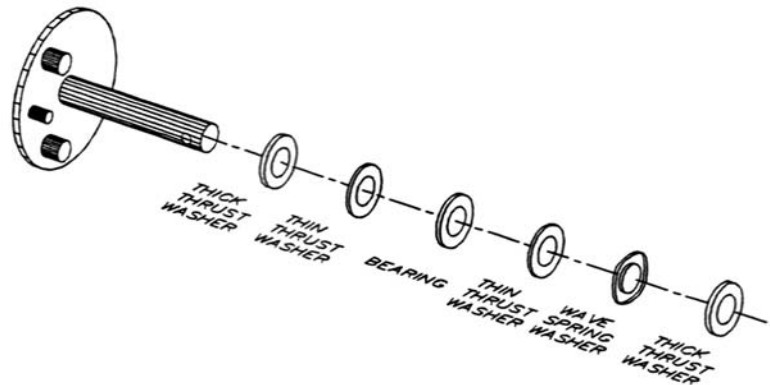

- 8] Remove and mount new spring plate with washers and bearing in the vice, with the inside surface of the spring plate flush with the top of the vice (shaft pointing upward) and tighten securely.

WASHER STACK

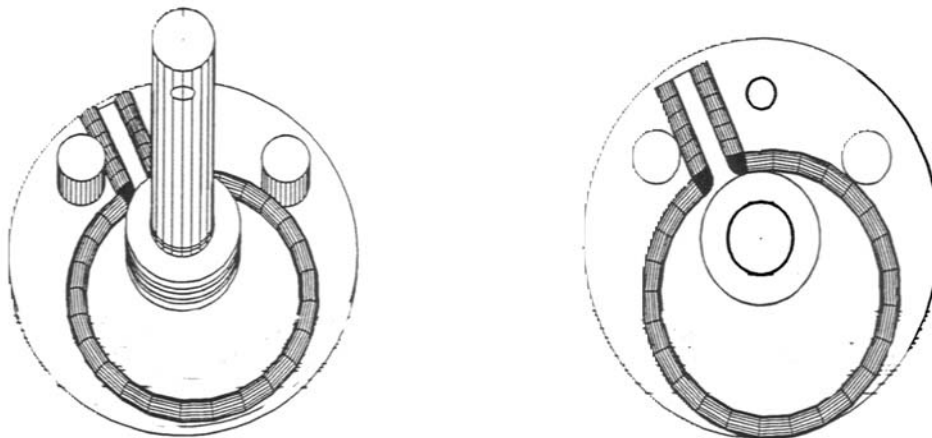

SPRING @ 11:00 POSITION

- 9] Refer to "spring installation diagrams". If the smaller pin of the plate is at the 12:00 o'clock position, the legs of the spring must be located at 11:00 o'clock, positioned between the larger and smaller pin.
- 10] Have a four inch piece of packing tape ready. Using the tapered Drift, twist the left-leg of the spring past the right leg and over the small pin while holding the spring flat against the plate with the other hand. Tap the legs down securely over the small pin (while still holding the spring against the plate). Then tap the legs of the spring towards the center of the plate so

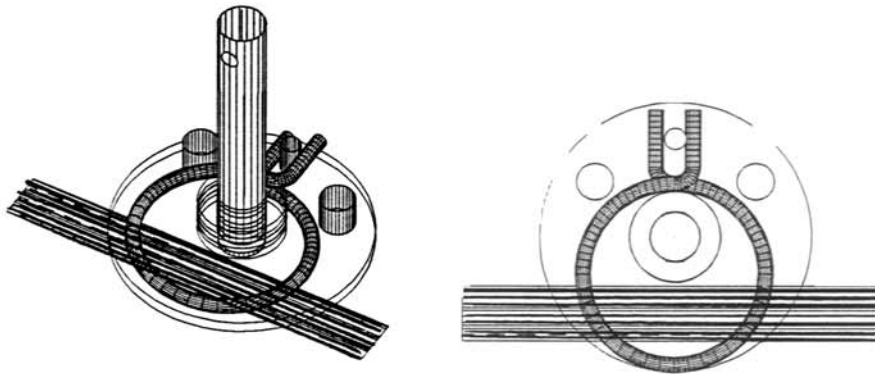

SPRING INSTALLED AND TAPED

that the legs do not overlap past the plate edge (while still holding the spring against the plate). Before removing your fingers from holding the spring against the plate, place the packing tape securely over the loop end of the spring and wrap the tape around the back side of the plate, leaving at least an inch on one end. The tape must be clear of the washers and bearing and must not wedge into them. [This procedure must be performed with extreme caution. The spring has a mind of its own. You and any helpers should be wearing safety glasses and leather gloves. The area should be cleared of innocent bystanders while mounting and installing spring.]

Apply a small amount of Krytox to the shaft of the gimbal plate, then slide it into the burner frame. Align the drive pins on the burner frame (which the black spring cup is positioned over) with the center of the legs of the spring. Slide into position.

Install the final washer removed during disassembly in step 5. Slide gimbal block onto shaft and align gimbal block holes with shaft hole. It may be necessary to use a "C" clamp to squeeze the assembly together.

Using 9/16" prop block under the gimbal block, drive roll pin into gimbal block and gimbal plate shaft. Remove tape from gimbal plate with a quick tug.

Repeat procedure (steps 3-13) for the other end of the burner. Make logbook endorsement per step 1. Fill out compliance card and return via regular mail or UPS ground along with spring plates removed from this burner to:

Dee Rose
Customer Service
Aerostar International, Inc.
1813 "E" Avenue, PO Box 5057
Sioux Falls, SD 57117