

AEROSTAR INTERNATIONAL, INC
SERVICE LETTER 106

NOVEMBER 7, 1994

SUBJECT: POLY SKID GUARD PROTECTORS
(Classic Limited{CW}, Classic Limited
Stretch{CWS}, Classic VIII{RB5}, Classic IX{RB6},
Classic X{RB8})

APPLICABILITY: All baskets with removable skids that have had poly skid protectors installed.

PROBLEM: There have been a few incidents of poly skid guards on the bottom of some baskets being damaged or broken on landing impact. Also the horizontal screws into the oak skids were located with minimal edge distance in the wood resulting in some splitting of the wood skid itself. Finally, the mitered corner joint of the skid guard was susceptible to snagging on ground during landing resulting in a kind of peeling action.

DISCUSSION: It was determined that anchoring the skid guards through the bottom with larger screws was more secure and less detrimental to the strength of the wood. A flat washer recessed into a counter bore increases the load bearing area and protects the fastener from abrasion damage.

The addition of a stainless steel corner bracket protects both the poly guards and the skids themselves from landing damage at this somewhat exposed joint. The bolt hole spacing is the same as the existing inside brace, and the new outside bracket merely takes the place of the previous washers.

PARTS REQUIRED

<u>QUANTITY</u>	<u>PART NUMBER</u>	<u>DESCRIPTION</u>
4	52987	Corner Bracket
**	51014-29	#12 x 2" Wood Screw
**	51017-18	Flat Washer

**Quantities vary per basket:

RB5	--	24
RB6	--	24
RB8	--	28

PROCEDURE: For the Classic Limited and Classic Limited Stretch baskets, follow Revision A, Report R-52412 dated 11/2/94 Retrofit Instructions, Skid Guards.

For Classic VIII, Classic IX, and Classic X use the following procedure:

CORNER BRACKETS

Remove (4) nuts, bolts, and washers at skid corner joint. install corner bracket overlapping skid guards as shown. Re-use existing inside corner brace (not shown). Re-use nuts and bolts (discard washers), tighten uniformly. Repeat above steps at other remaining corners.

SKID GUARD SCREWS

Location of the screws should be in approximately the same location as the current screws in the side of the skid. However, show caution that they do not interfere with the integrity of the skid board. Counterbore guards 1" dia. x 3/16" deep at locations indicated. Drill 9/64" pilot hole 1 3/4" into skid for #12 x 2" wood screws. Install flat washer and #12 x 2" wood screws as shown. Use soap or other lubricant to prevent overheating of screws.

Illustration One

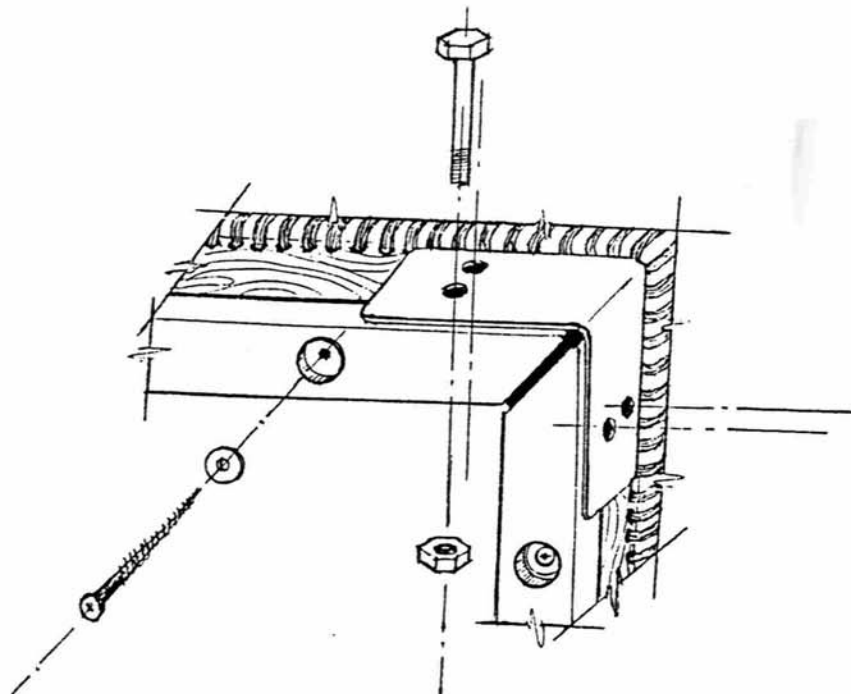

Page Three
Service Letter 106
November 7, 1994

An Appropriate logbook entry shall be made following completion of the work by authorized personnel at an approved facility.

If you have any questions contact:

Dee Rose
Customer Service Manager
AEROSTAR INTERNATIONAL, INC.
P.O. BOX 5057
SIOUX FALLS, SOUTH DAKOTA 57117
PHONE: 605-331-3500
FAX: 605-331-2547